







PART LIST

# ASSEMBLY INSTRUCTION-CAPTIVA

A		#4	1pcs	B		M6*40	4pcs
C		M6*15	4pcs	D		Washer	8pcs

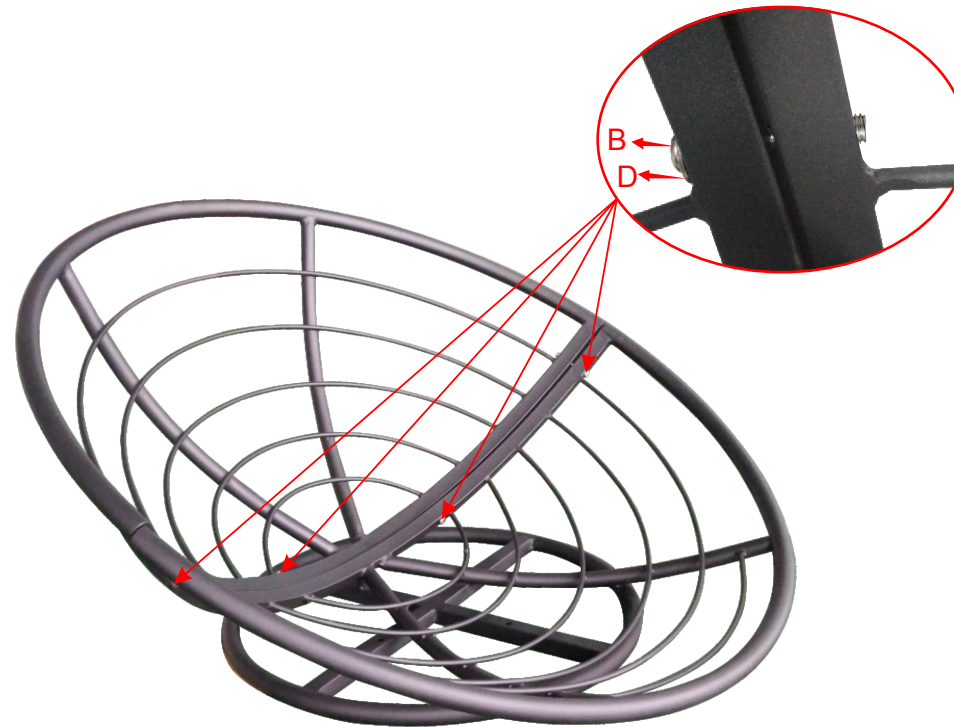

**STEP 1:**

Use screw B(M6x40mm) and insert washer D to the head of the screw. Securely tighten all screws.

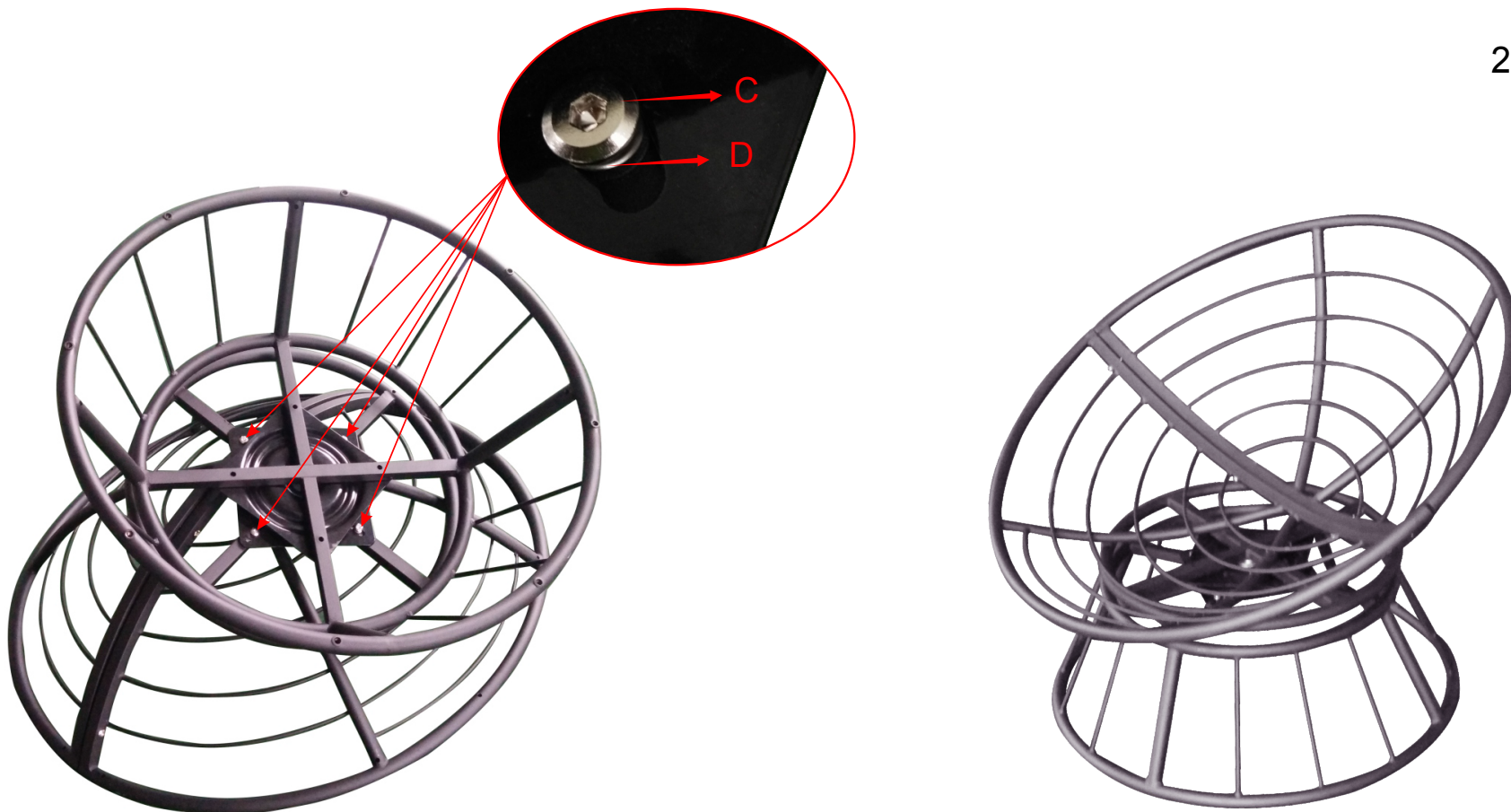
**STEP 2:**

Use screw C (M6x15mm) and washer D. Turn the swivel mechanism diagonally to better access the screw holes. Securely tighten all screws.

[www.mixmultifamily.com](http://www.mixmultifamily.com)

Assembly videos available at: [www.youtube.com/matriximportsusa](http://www.youtube.com/matriximportsusa)

Weather resistant synthetic wicker features UV protection to keep its color and shape all year long. A damp cloth is all you need to keep your product looking beautiful after use. Avoid the use of any abrasive cleaners and power washers. Clean fabric immediately if spill occurs. To minimize the fading effects and extend the vibrancy of the fabric it is recommended that outdoor cushions and pillows be stored in a deck box or covered when not in use. Lubricate metal components every 6 months to preserve functionality. Do not use power tools to assemble this product.



## Warranty Disclaimer

This Limited Warranty applies to physical goods, and only for physical goods, purchased from Matrix Imports Inc ("Mix Multifamily").

### **What does this limited warranty cover?**

This Limited Warranty covers any defects in material or workmanship under normal use during the Warranty Period.

During the Warranty Period, Mix Multifamily will repair or replace, at no charge, products or parts of a product that proves to be defective due to improper material or workmanship, under normal use and maintenance.

### **What will we do to correct problems?**

Mix Multifamily will either repair the Product at no charge, using new or refurbished replacement parts within the United States upon availability.

### **How long does the coverage last?**

The Warranty Period for Physical Goods purchased from Matrix Imports is 1-year from the date of purchase.

A replacement Physical Good or part assumes the remaining warranty of the original Physical Good or 90 days from the date of replacement or repair, whichever is longer.

### **What does this limited warranty not cover?**

Our products are not under warranty for damage to upholstery, printed table tops, wood or metal finishes nor damages which result from neglect, accident, intentional misuse or acts of nature such as lightning, floods, earthquakes, normal wear and tear, exposure to extremes in temperature or humidity, immersion in water, fading or variations in color or finish over time, scratches, blemishes or slight color variations in wood grain, minor variations in size, unauthorized repair, damages caused to assembly with power tools for assembly, alteration, abuse or misuse of Product, lack of routine proper maintenance, use of abrasive or improper cleaners, damages occurred in transit by a delivery carrier used by customer, other persons, pets, or rodents.

### **What do you have to do?**

To obtain warranty service, you must first contact us by e-mail at [customercare@mixmultifamily.com](mailto:customercare@mixmultifamily.com) to determine the problem and the most appropriate solution for you. Please include a Proof of Purchase from the Retailer/Dealer where you acquired your product.